

## Fanless Systems

# VIA AMOS-5002

Fanless, Compact Embedded System by EITX-3002



(with HDD)

## Features

- High, scalable performance
- Quick installation, convenient to setup and easy maintenance
- Built-in rich I/O functional feature cutouts for easy external access
- Fanless, compact slim size and robust casting construction
- Supports two USB 2.0

## Specifications

Model Name	AMOS-5002-L	AMOS-5002-H		
<b>Chassis Construction</b>	<b>Dimension</b>	250.2 mm (W) x 41 mm (H) x 123.5 mm (D)	250.2 mm (W) x 58 mm (H) x 123.5 mm (D)	
	<b>Construction</b>	Aluminum top cover Dual front & rear metal face plate		
	<b>Weight</b>	1.5 Kg	2.1 Kg	
	<b>Wall Mounting</b>	Removable wall/table mountable brackets at left & right		
	<b>VESA Mounting</b>	Reserved 100 mm x 100 mm VESA mounting holes on the bottom of system chassis		
<b>Front I/O Ports</b>	<b>LED</b>	1 x Green color LED to indicate power on/off 1 x Red color LED to indicate storage activities status		
	<b>COM</b>	2 x Front-access D-Sub 9-pin connectors (COM 1, COM 2)		
	<b>USB 2.0</b>	Supports 2 x Front-access USB 2.0 host ports by a double-deck of mini-DIN USB connector		
	<b>Power Input</b>	1 x 2-pole Phoenix power input connector		
	<b>Power On/Off Switch</b>	1x ATX Power on/off button		
<b>Rear I/O Ports</b>	<b>VGA</b>	1 x Rear-access D-sub 15-pin VGA connector		
	<b>COM</b>	N/A	2 x Front-access D-Sub 9-pin connectors (COM 3, COM 4)	
	<b>HDMI</b>	1 x Rear-access single-link HDMI connector		
	<b>Dual Gigabit LAN</b>	2 x Rear-access RJ-45 connectors		
	<b>Audio</b>	2 x Rear-access 3.5Φ audio jack connectors support Speaker-Out and Mic-In via cables		
<b>Storage</b>	<b>CFast</b>	1 x Rear-access of CFast socket support CFast Flash disk		
	<b>HDD</b>	N/A	1 x 2.5" SATA hard disk drive bay	
<b>Environmental Specifications</b>	<b>Operating Temperature</b>	When system running through PXE boot from LAN to server without installing any storage unit is: -20°C up to 55°C With industrial grade CFast Flash disk only: -20°C up to 50°C With hard disk drive only: 0°C up to 45°C		
	<b>Storage Temperature</b>	-20°C ~ 60°C		
	<b>Relative Humidity</b>	0 ~ 90% @ 45°C, non-condensing		
	<b>Vibration Loading During Operation</b>	With CFast Flash disk: 5Grms, IEC 60068-2-64, random, 5 ~500Hz, 1 Oct./min, 1hr/axis	With hard disk drive: 1Grm, IEC 60068-2-64, random, 5 ~500Hz, 1 Oct./min, 1hr/axis	
	<b>Shock During Operation</b>	With CFast Flash disk: 50G, IEC 60068-2-27, half size, 11ms duration	With hard disk drive: 20G, IEC 60068-2-27, half size, 11ms duration	



## AMOS-5002-L

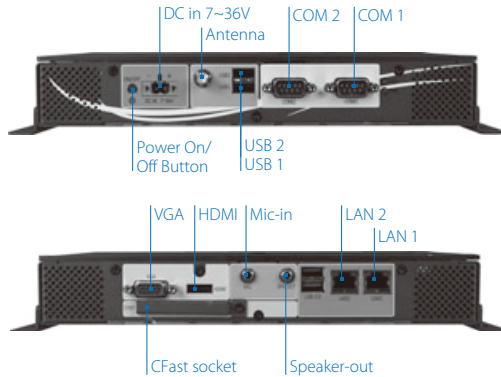

## AMOS-5002-H

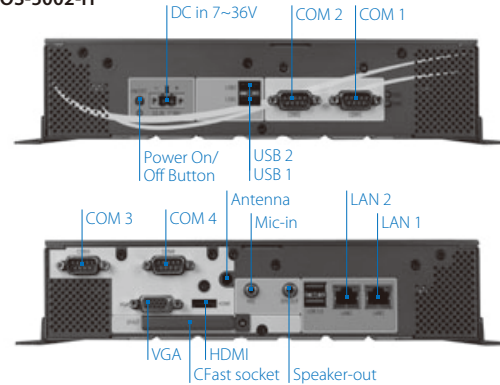

## Ordering Information

Part Number	Description
AMOS-5002-1D10A1 (AMOS-5002-L)	AMOS Embedded System with Eden™ X2 1.0GHz EITX-3002 Em-ITX Board, 1 x VGA, 1 x HDMI, 2 x RS-232/422/485, 2 x GigaLAN, 2 x USB 2.0, 1 x CFast, 1 x MIC-in and 1 x Speaker-out
AMOS-5002-1D12A1 (AMOS-5002-L)	AMOS Embedded System with Nano™ X2 E 1.2GHz EITX-3002 Em-ITX Board, 1 x VGA, 1 x HDMI, 2 x RS-232/422/485, 2 x GigaLAN, 2 x USB 2.0, 1 x CFast, 1 x MIC-in and 1 x Speaker-out
AMOS-5002-2D10A1 (AMOS-5002-H)	AMOS Embedded System with Eden™ X2 1.0GHz EITX-3002 Em-ITX Board, 1 x VGA, 1 x HDMI, 4 x RS-232/422/485, 2 x GigaLAN, 2 x USB 2.0, 1 x CFast, 1 x MIC-in, 1 x Speaker-out and 1 x SATA HDD Bay

## Optional Accessories

\*Note: The optional accessories may have minimum ordering quantity limitation. Please contact VIA Sales representative for more details.

### External AC-to-DC Adapter and Power Cable

Part Number	Description
99G63-020246	AC-to-DC adapter, 2-pole, DC 19V/90W with Phoenix power plug
99G33-02032C	Power Cable, 180 cm, USA type
99G33-02033C	Power Cable, 180 cm, Europe type
99G33-02031C	Power Cable, 180 cm, UK type
99G33-02034C	Power Cable, 180 cm, with PSE mark type for Japan

### WLAN USB Module

Part Number	Description
EMIO-1530-A5A1	802.11 b/g Wireless LAN USB module for USA
EMIO-1530-A6A1	802.11 b/g Wireless LAN USB module for Europe
EMIO-1533-00A1	802.11 b/g/n Wireless LAN USB Module with assembly kit

## Dimensions

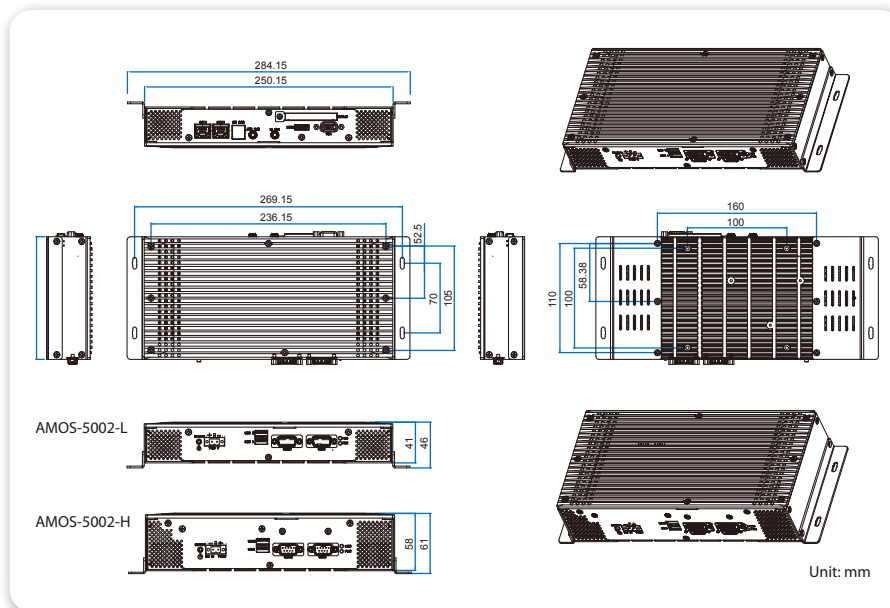

## Packing List

- 1 x AMOS-5002 Chassis Kit
- 1 x 2-pole Power Cable with phoenix power plug to DC-in
- 1 x Screws package