

Datasheet

2.5" SATA SSD

2IE series

- iSLC technology
- Perfect replacement for traditional hard disk
- iSMART disk health monitoring
- Intelligent error recovery system
- Excellent data transfer speed
- Enhanced power cycling management



Introduction

iSLC [2IE series], designed to outdo the endurance, performance and reliability of MLC-based solutions. Through the use of flash management algorithms, iSLC improves SSD endurance up to 30,000 times, increasing lifespans up to 10 times longer than MLC-based solutions. In addition, iSLC improves the performance of solid state drives, with similar write performance of SLC-based solutions, and with data quality that is on par with SLC technologies. The Innodisk iSLC series is cost efficient, boasting excellent benefits at only half the price of SLC-based solutions.

2.5" SATA SSD

2IE series

Drawing

Contact us for more information about the 2.5" SATA SSD 2IE

Innodisk is a service-driven provider of industrial embedded flash and DRAM storage products and technologies, with a focus on the industrial/embedded, aerospace and defense, and cloud computing industries.

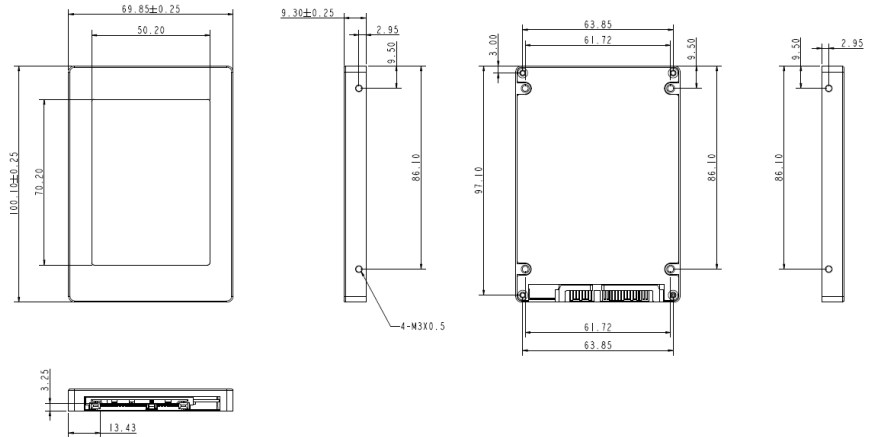

Specifications

Interface	SATA II
Flash Type	iSLC
P/E cycle limit	30,000
Capacity	32GB~256GB
Max. Channels	8
Sequential R/W (MB/sec, max.)	230 / 230
Max. Power Consumption	2.1 W (5V x 428 mA)
Thermal Sensor	√
H/W Write Protect	√
Pin7 Power	-
ATA Security	Supported
S.M.A.R.T.	Supported
Dimension (WxLxH)	69.85 X 100.10 X 9.30 mm
Environment	Vibration: 20G @7~2000Hz Shock: 1500G @ 0.5ms Storage Temperature: -55°C ~ +95°C MTBF: 3 million hours

Headquarters (Taiwan)

9F., No.100, Sec. 1, Xintai 5th Rd.,
Xizhi Dist., New Taipei City,
Taiwan (R.O.C.)
Tel: +886-2-26963000
Email: sales@innodisk.com

Branch Offices:

USA
usasales@innodisk.com
+1-510-770-9421
Europe
eusales@innodisk.com
+31-040-282-2382
Japan
jpsales@innodisk.com
+81-3-6661-9846
China
sales_cn@innodisk.com
+86-755-21673689
www.innodisk.com

© 2012 Innodisk Corporation.
All right reserved. Specifications
are subject to change without
prior notice.

20130110

Ordering Information

Operation Temp.	32GB	64GB	128GB	256GB
Standard Grade (0°C ~ +70°C)	DHS25- 32GJ201C1EN	DHS25- 64GJ201C1EN	DHS25- A28J201C1EN	DHS25- B56J201C1EN

innodisk

www.innodisk.com